

ROAD COMMISSION FOR OAKLAND COUNTY

SPECIAL PROVISION
FOR
**DR STRUCTURE COVER, ADJ, CASE 1, RCOC AND
PUBLIC UTILITY STRUCTURE, ADJ, CASE 1, RCOC**

RCOC/DESIGN:JR/JO

PAGE 1 OF 4

RCOC20SP403B

ORG:03-29-22

a. Description

This work shall consist of adjusting drainage structure covers and public utility structure covers in accordance with section 403, 602, 603, 905, 914 and 1004 of the *Michigan Department of Transportation (MDOT) 2020 Standard Specifications for Construction* except has herein provided.

b. Materials

Provide materials in accordance with subsection 403.02 of the *MDOT 2020 Standard Specifications for Construction* with the following exceptions:

Provide Concrete, Grade 3500 or 3500HP in accordance with section 1004 of the *MDOT 2020 Standard Specifications for Construction* and meet ASR requirements. Provide epoxy anchored lane ties in accordance with section 905 of the *MDOT 2020 Standard Specifications for Construction*. The lane ties must be #5 bar size with a nominal length of 18 inches. The circular bar for the rotary cut application must be epoxy coated #5 bar of a diameter that will center it between the structure cover and the existing surrounding pavement. Select epoxy for anchoring lane ties into the concrete from section 7.12.03J of the Qualified Products List. Provide hot-poured joint sealant in accordance with section 914 of the *MDOT 2020 Standard Specifications for Construction*.

c. Construction

Permit and Inspection Requirements for Public Utility Structures.

Permit and inspection may be required. For more details regarding financial requirements, refer to the *Special Provision for Permits and Inspection Fees*.

The Contractor must fulfill all permit requirements as applicable, including but not limited to, posting of all required fees, bonds, and insurance, and provide notice to the public utility owner in order to schedule and fulfill any and all inspection requirements.

Before start of work, the public utility owner or their representatives, RCOC, and the Contractor shall meet and collectively inspect each structure prior to beginning work

and make a determination as to the type of treatment that is necessary. The Contractor shall arrange this meeting and verify all owners are at meeting prior to starting work.

All structures are to be opened by the Contractor for inspection by the Engineer and Utility representatives for confirmation and/or change of adjustment and reconstruction quantities prior to beginning any work. Payment for inspection of structures shall be paid as part of the structure adjustment items. When work is being performed, the Contractor shall notify the Engineer and utility owner (utility, city, OCWRC, etc.) for inspection. Final work shall not be accepted until written acceptance is received from the utility owner. All structures are to be opened by the Contractor for inspection by the Engineer and Utility representatives for final inspection.

The Contractor shall record the location of the structure so each cover can be reinstalled at its original location. The method for recording the structure locations must be approved by the Engineer prior to starting work. The Contractor is responsible for field locating the cores.

For structures within the pavement area, remove pavement adjacent to the drainage structure cover using a rotary coring method. The rotary core shall remove a minimum 4-foot diameter section of pavement around the drainage structure frame and cover. If the frame outside diameter measurement is greater than 36 inches, use a rotary coring head to remove a minimum 4.5-foot diameter section of pavement.

Prior to setting the frame compact exposed soil using a method approved by the Engineer.

Support the cover frame over the structure matching the adjacent roadway cross slope. Secure the frame in-place to allow for placement of concrete using brick or block as required on a full bed of mortar without altering frame position.

The structure rim shall be within 0.25 inches of final elevation of HMA or concrete pavement using the 10-foot straight edge method. Corrections to meet this tolerance are at the contractor's cost.

Install epoxy anchored lane ties in accordance with section 603 of the *MDOT 2020 Standard Specifications for Construction* to anchor the concrete to adjacent composite pavement where applicable or as directed by Engineer. Install circular epoxy coated bar as detailed below. Once pavement is removed and structure cover is adjusted, replace pavement around the frame with Concrete, Grade 3500 or 3500HP matching the finished elevation and cross-slope of the roadway. Construct plane of weakness joints when square structure covers are adjusted or as directed by the Engineer. Immediately remove any debris that falls into drainage structures or other utility manholes due to Contractor operations.

Do not overcut into adjacent paving when constructing plane of weakness joints.

d. Measurement and Payment

The completed work, as described, will be measured and paid for at the contract unit price using the following payitem:

Pay Item	Pay Unit
Dr Structure Cover, Adj, Case 1, RCOC	Each
Public Utility Structure Cover, Adj, Case 1, RCOC	Each

Dr Structure Cover, Adj, Case 1, RCOC and Public Utility Structure Cover, Adj, Case 1, RCOC includes:

1. Furnishing and placement of all materials described above
2. Removal and disposal of existing pavement and debris
3. Cleaning and sealing joints with hot-poured joint sealant
4. Constructing plane of weakness joints, as directed by the Engineer
5. Salvaging and reusing existing cover and frame, as directed by the Engineer
6. Cost of repairs for uniform contact of temporary steel plate to the top of structures
7. Providing, placing and removal of temporary plating of the structure
8. Temporary lowering of the structures including:
 - A. Match marking for later identification and placement of covers;
 - B. Record the location of the structure so each cover can be reinstalled at its original location
 - C. Removing, salvaging, and transporting castings to and from site;
 - D. Storing the existing structure castings;
 - E. Temporary plating the structure. Plate materials shall meet *MDOT 2020 Standard Specifications for Construction* section 403.02.
 - F. HMA patching;
 - G. Removing the temporary plate and HMA patching materials for final adjustment.
9. Existing structure covers that have been replaced are to be disposed of in a legal manner off the project by the Contractor included in the structure adjustment pay items.

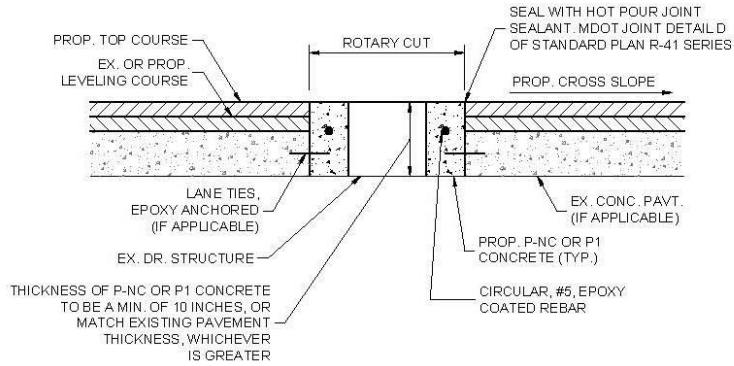

PAVEMENT AREAS - ELEVATION VIEW

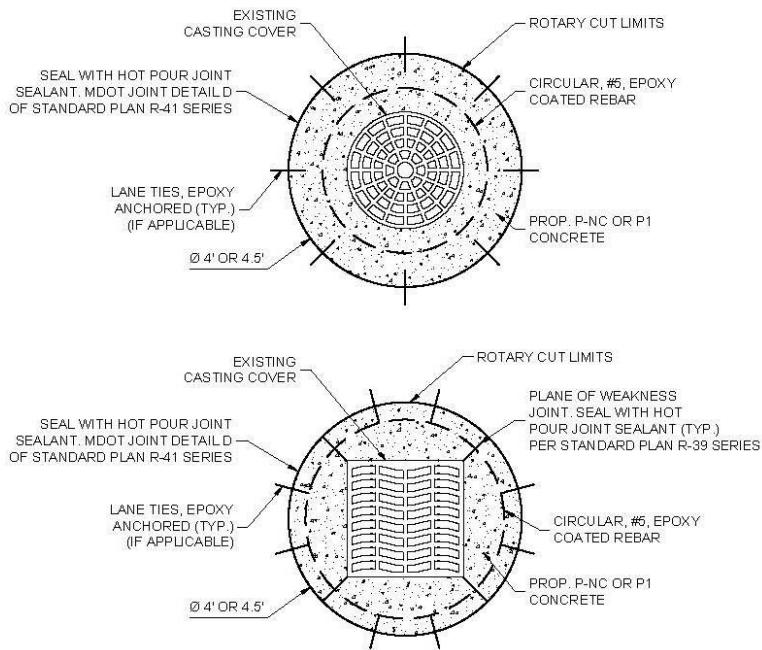

PAVEMENT AREAS - PLAN VIEW

PAVEMENT REMOVAL AND REPAIR DETAIL FOR
DR. STRUCTURE COVER, ADJ, CASE 1, RCOC
OR
PUBLIC UTILITY STRUCTURE COVER, ADJ CASE 1, RCOC